



JUPITER AVIONICS
C O R P O R A T I O N

JRS28-001
Relay Switch



Installation and Operating Manual

Rev. C

Jupiter Avionics Corporation
1959 Kirschner Road
Kelowna BC
Canada V1Y 4N7
Tel: %778'478'2232
Toll-Free: %855'478'2232
www.jupiteravionics.com



Table of Contents

SECTION 1 - DESCRIPTION	1
1.1 System Overview	1
1.2 Features Overview	1
1.2.1 Functionality	1
1.2.2 Emergency procedures	1
1.3 Inputs and Outputs	2
1.3.1 Inputs	2
1.3.1 Outputs	2
1.4 Specifications	2
1.4.1 Electrical Specifications	2
1.4.2 Physical Specifications	3
SECTION 2 – INSTALLATION.....	4
2.1 Introduction.....	4
2.2 Continued Airworthiness	4
2.3 Unpacking and Inspecting Equipment	4
2.3.1 Warranty.....	4
2.4 Installation Procedures.....	4
2.4.1 Cabling and Wiring	4
2.4.2 Mechanical Installation	5
2.4.3 Post Installation Checks.....	5
2.5 Adjustments.....	6
2.6 Installation Kit.....	6
2.6.1 Recommended Crimp tools.....	6
2.7 Installation Drawings	6
SECTION 3 – OPERATION	7
3.1 Introduction.....	7
Appendix A.....	A1
A1 Introduction.....	A1
A2 Installation Drawings	A1



JRS28-001 Relay Switch

SECTION 1 - DESCRIPTION

1.1 System Overview

The JRS28-001 Relay Switch is a compact, high-density, bulkhead-mounted remote switching unit that provides twenty-eight “C style” contacts to handle the switching requirements of navaid, audio, and other interface applications. It allows up to 28 data or audio lines to be transferred with a single control line.

The JRS28-001 Relay Switch consists of two completely independent units packaged in one enclosure.

1.2 Features Overview

The JRS28-001 features industry standard interconnects to allow easy field upgrades.

The JRS28-001 provides switching for 28 contacts of information, organized as six groups of two 2PDT relays and two groups of one 2PDT, each with an individual key line. Each group can be used independently, or can be picked as two groups (14 contact sets), or can be picked as one group by applying the required logic level to the appropriate ALL GROUP KEY line.

This relay switch can be used for applications from dry circuit to 0.5 A switching, but is limited to a maximum of 30 Vdc. It can be operated from +18 to +33 Vdc without changing the interconnect.

All interconnect and relay contacts are gold plated. Relays are sealed, high vibration rated (50g shock), dry nitrogen filled units.

All relay switches have a contact rating of 1 amp/30 Vdc

1.2.1 Functionality

The JRS28-001 provides remote switching of navigation or audio signals to allow system expansion or interconnection. Once installed, it operates independently to provide the required switching functions without any operator action.

1.2.2 Emergency procedures

The JRS28-001 does not affect the emergency procedures of the aircraft. If the unit is used to switch navigation signals, flight personnel should be made aware of its function.



1.3 Inputs and Outputs

Refer to the JRS28-001 connector map for the mating connector designators and pin assignments for the input and output signals..

1.3.1 Inputs

Refer to the JRS28-001 connector map drawing for the mating connector designators and contact assignments for the JRS24 input signals.

Input	Quantity	Type
GROUP KEY	8	active low
ALL GROUP KEY	2	active low
POWER INPUT and POWER GROUND	4	power
Signal inputs	28	common

1.3.1 Outputs

Refer to the JRS28-001 connector map drawing for the mating connector designator and contact assignments for the JRS24 output signals.

Output Type	Quantity
Normally open signal outputs	28
Normally closed signal outputs	28
Bias voltage output contacts	2

1.4 Specifications

1.4.1 Electrical Specifications

Power Input

Nominal voltage	28 Vdc
Maximum voltage	30.3 Vdc
Minimum voltage	22.0 Vdc
Emergency voltage	18.0 Vdc
Input current	≤ 0.2 A max @ 28 Vdc

1.4.1.1 Audio Performance

Rated Input Level

Audio rated input level	7.75 Vrms±10%
-------------------------	---------------

Rated Output Power

Audio rated output power	7.75 Vrms±10%
--------------------------	---------------

Audio Frequency Response

Audio output audio frequency response	≤3dB from 300 to 6000 Hz
---------------------------------------	--------------------------

Distortion Characteristics

Audio output distortion at rated power	≤10%
Audio output distortion at 10% of rated power	≤3%



Input to output Crosstalk and Bleed-through Level

Input to output Crosstalk ≤ 55 dB

Input to Input Crosstalk Level

Input to Input crosstalk ≤ 60 dB

Audio Noise Level without Signal

Noise level below the rated output ≥ 60 dB

1.4.1.2 Control Signal Performance

Discrete Signals

Active low control input shall be active when the signal is $\leq +3$ Vdc

Active low control input shall be inactive when the signals is $\geq +10$ Vdc

Active low control input signals, when active, shall source ≤ 20 mA

Output signals, when active, shall sink ≤ 1 A

1.4.2 Physical Specifications

Height (maximum) 2.15" [54.6 mm]

Overall depth (maximum) 2.61" [66.2 mm]

Width (maximum) 4.52" [114.8 mm]

Weight (maximum) 0.48 lbs [0.22 g]

Material brushed aluminum with conversion coating

Connectors Two 50 pin D-Sub male, V5 locking

Mounting Four 10-32 screws

Bonding ≤ 2.5 m Ω

Installation kit part number INST-JRS2x



SECTION 2 – INSTALLATION

2.1 Introduction

This section contains unpacking and inspection procedures, installation information, and post-installation checks.

2.2 Continued Airworthiness

Maintenance of the JRS28-001 is on condition only. Scheduled inspection and/or periodic maintenance of this unit is not required.

2.3 Unpacking and Inspecting Equipment

Unpack the equipment carefully. Check for any obvious shipping damage and report any problems to the relevant carrier. Confirm that the Certificate of conformity or release certification is included. Complete the on-line warranty card from the Jupiter Avionics Corporation (JAC) website – www.jupiteravionics.com/warranty.

2.3.1 Warranty

All products manufactured by JAC are warranted to be free of defects in workmanship or performance for 2 years from the date of installation by an approved JAC dealer or agency. This warranty covers the cost of all materials and labour to repair or replace the unit, but does not include the cost of transporting the defective unit to and from JAC or its designated warranty repair centre, or of removing and replacing the defective unit in the aircraft. This warranty does not cover failures due to abuse, misuse, accident, or unauthorized alteration or repairs.

THIS WARRANTY IS VOID IF THE PRODUCT IS NOT INSTALLED BY AN AUTHORIZED JAC DEALER. If the on-line warranty card is not completed, the product will be warranted from the date of manufacture.

Contact JAC for return authorization, and for any questions regarding this warranty and how it applies to your unit(s). JAC is the final arbiter concerning warranty issues.

2.4 Installation Procedures



CAUTION: The power input circuitry of the unit may be damaged if the installation does not conform to the wiring instructions and circuit breaker rating in this manual.

2.4.1 Cabling and Wiring

All wire shall be selected in accordance with the original aircraft manufacturer's maintenance instructions, or AC43.13-1B Change 1, Paragraphs 11-76 through 11-78. Unshielded wire types shall qualify to MIL-W-22759 as specified in AC43.13-1B Change 1, Paragraphs 11-85, 11-86, and listed in Table 11-11. For shielded wire applications, use Tefzel MIL-C-27500 shielded wire with solder sleeves (for shield terminations) to make the most compact and easily terminated interconnect. Follow the Connector Map in Appendix A of this manual.

Allow 3" from the end of the shielded wiring to the shield termination to allow the connector hood to be easily installed. Refer to the Interconnect drawing in Appendix A of this manual for shield termination details. Note that this unit has a 'clamshell' hood that is installed after the wiring is complete.

Maintain wire segregation and route wiring in accordance with the original aircraft manufacturer's maintenance instructions.



Unless otherwise noted, all wiring shall be a minimum of 24 AWG, except power and ground lines, which shall be a minimum of 20 AWG. Refer to the Interconnect drawing for additional specifications. Check that the ground connection is clean and well secured, and that it shares no path with any electrically noisy aircraft accessories such as blowers, turn-and-bank instruments, or similar loads.

2.4.2 Mechanical Installation

The JRS28-001 can be mounted in any attitude and location with adequate space and sufficient clearance for the connector and wiring harness. It requires no direct cooling and no shock or vibration isolators are required.

2.4.2.1 Installation Considerations

If the JRS28-001 is to be used for NAV switching, for instance linking two sources to a common indicator, this must be clearly marked and placarded in the aircraft. External annunciation of any NAV source must comply with section 2.4.2.2 of this manual.

If the unit is to be used for GPS/MLF switching, it may be necessary to wire the unit to ensure that it returns to the VOR/ILS mode when the navigation receiver is tuned to an ILS frequency. Check local aviation regulations regarding this requirement.



NOTE: ILS reversion mode for NAV/GPS installations is not applicable in Canada.

2.4.2.2 External Switches and Lamps

All switches and/or annunciators must be selected to suit the application. A single pushbutton or toggle switch may be used to supply the ALL GROUP KEY line to allow all lines to be selected together. If a single switch or lamp assembly is used to replace the transfer switch and annunciators, it should be a lighted pushbutton switch (SPST/SPDT) with a positive action (i.e. push on/push off) with two legends to match the required NAV functions.

If the unit is to be used as audio key relays for boom mics etc., the unit can be triggered by in-line drop cords or similar ways that supply an input to the appropriate key line.

If it is to be used as a NAV selector, annunciator lights should be connected through one or more relay contacts to ensure correct indication of the actual relay contacts.

2.4.3 Post Installation Checks

2.4.3.1 Voltage/Resistance checks.

Do not attach this unit until the following conditions are met:

- a) Check P1 pin **17** for +28 Vdc relative to ground.
- b) Check P1 pin **34** for continuity to ground (less than 0.5 Ω).
- c) Check P1 pins **47 - 50** for continuity to ground (less than 0.5 Ω) when the relevant switch is closed.
- d) Check all pins for shorts to ground or adjacent pins.

Repeat this procedure for connector P2.

2.4.3.2 System Operation

All operation is described with aircraft electrical power supplied, unless stated otherwise.

Individual Relay Key Operation

The individual relay common contacts connect to the Normally Open signal contacts when the GROUP (1 thru 4) KEY input is active.

The individual relay common contacts connect to the Normally Closed signal contacts when the GROUP (1 thru 4 and ALL) KEY input is not active.



All Relay Key Operation

The all relay common contacts connect to the Normally Open signal contacts when the ALL GROUP KEY input is active.

Bias Resistor Operation

The bias resistors provide an electrical current on a continuous basis

2.4.3.3 Power on Checks.

Power up the aircraft's systems and check that all switching functions transfer correctly with the appropriate relay action. If the internal flag bias is used for indicator interfacing, ensure that this function works correctly, and only in the selected or transferred position.

When all performance checks are satisfied, complete the necessary regulatory documentation before releasing the aircraft for service.

2.5 Adjustments

The JRS28-001 unit has no internal mechanical adjustments.

2.6 Installation Kit

The kit required to install this unit is not included with the unit.

The JRS28 requires one installation kit (Part # INST-JRS2x) which consists of the following:

Quantity	Description	JAC Part #
2	D-sub 50-pin Connector Assembly	CON-3420-0050
2	TAG ring	CON-5500-0625
2	Heatshrink Tubing	WIR-HTSK-1000

2.6.1 Recommended Crimp tools

Connector Type	Hand crimp tool	Positioner	Insertion/extraction tool
Positronic	9507	9502-3	M81969/1-04

2.7 Installation Drawings

The drawings and documents required for Installation can be found in [Appendix A](#) of this manual.

JRS28-001 Relay Switch

SECTION 3 – OPERATION

3.1 Introduction

The JRS28-001 has no operator controls.

If any switches or indicators have been installed to control or indicate the function of the unit, confirm their operation with the installing agency and ensure that the relevant information has been added to the flight manual where necessary.



Installation and Operation Manual

Appendix A - Installation Drawings

A1 Introduction

The drawings necessary for installation and troubleshooting of the JRS28-001 Relay Switch are in this Appendix, as listed below.

The JRS28-001 Relay Switch consists of two completely independent units packaged in one enclosure.

A2 Installation Drawings

DOCUMENT	REV
JRS28-001 Connector Map	B
JRS28-001 Interconnect	B
JRS28-001 Mechanical Installation	C

P1

50 PIN FEMALE DMIN MATING CONNECTOR

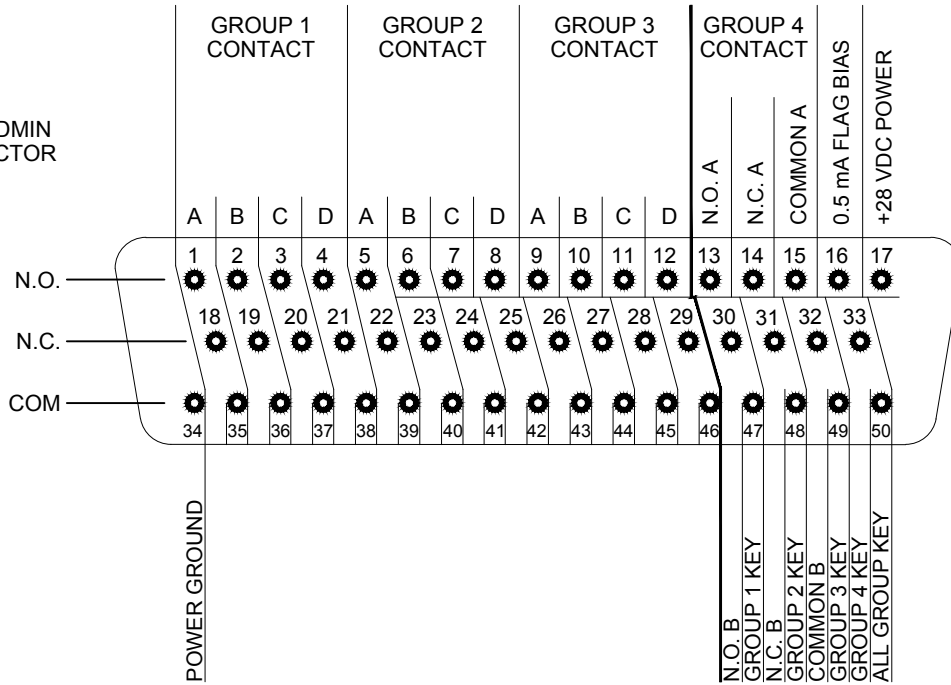

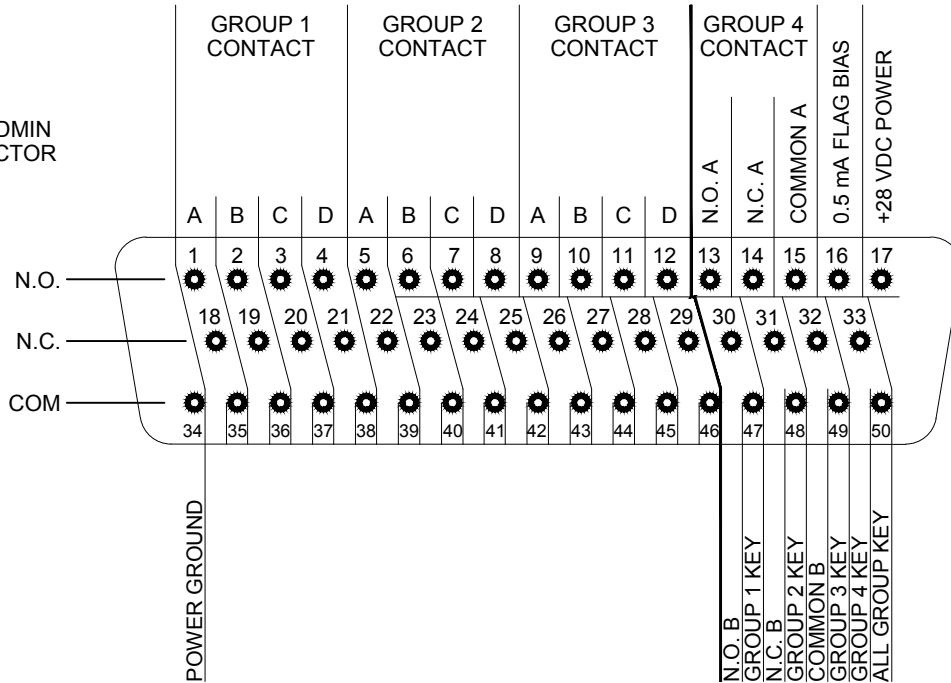

P2

50 PIN FEMALE DMIN MATING CONNECTOR



VIEW IS FROM REAR OF MATING CONNECTOR



PREPARED	TAT			
CHECKED				
APPROVED		NCAGE CODE	PART NO.	SHEET
CONFIDENTIAL & PROPRIETARY TO JUPITER AVIONICS CORP.		L00N3	JRS28-001	1/1
		DOC NO. JRS28-001 Connector Map Rev B.dwg		

JRS28-001 INTERCONNECT WIRING NOTES

NOTES

1. ALL WIRE SIZE SHOULD BE 24 AWG MIN UNLESS OTHERWISE SPECIFIED. UNSHIELDED WIRE SHOULD BE SELECTED PER FAA AC43.13-1B CHANGE 1 PARA 11-76 TO 11-78. WIRE TYPES SHOULD BE IN ACCORDANCE WITH MIL-W-22759 AS DESCRIBED IN FAA AC43.13-1B CHANGE 1 PARA 11-85 AND 11-86 AND LISTED IN TABLE 11-11 OR 11-12. ALL SHIELDED CABLE SHOULD BE IN ACCORDANCE WITH MIL-DTL-27500 (REVISION H OR LATER).

 CONNECTION TO AIRFRAME GROUND SHOULD BE MADE WITH 20 AWG WIRE. LENGTH NOT TO EXCEED 3 FT (0.91 M).

PREPARED	TAT			
CHECKED				
APPROVED		Relay Switch 28 Contacts		SHEET
CONFIDENTIAL & PROPRIETARY TO JUPITER AVIONICS CORP.		NCAGE CODE L00N3	PART NO. JRS28-001	1/3
		DOC NO. JRS28-001 Interconnect Rev B.dwg		

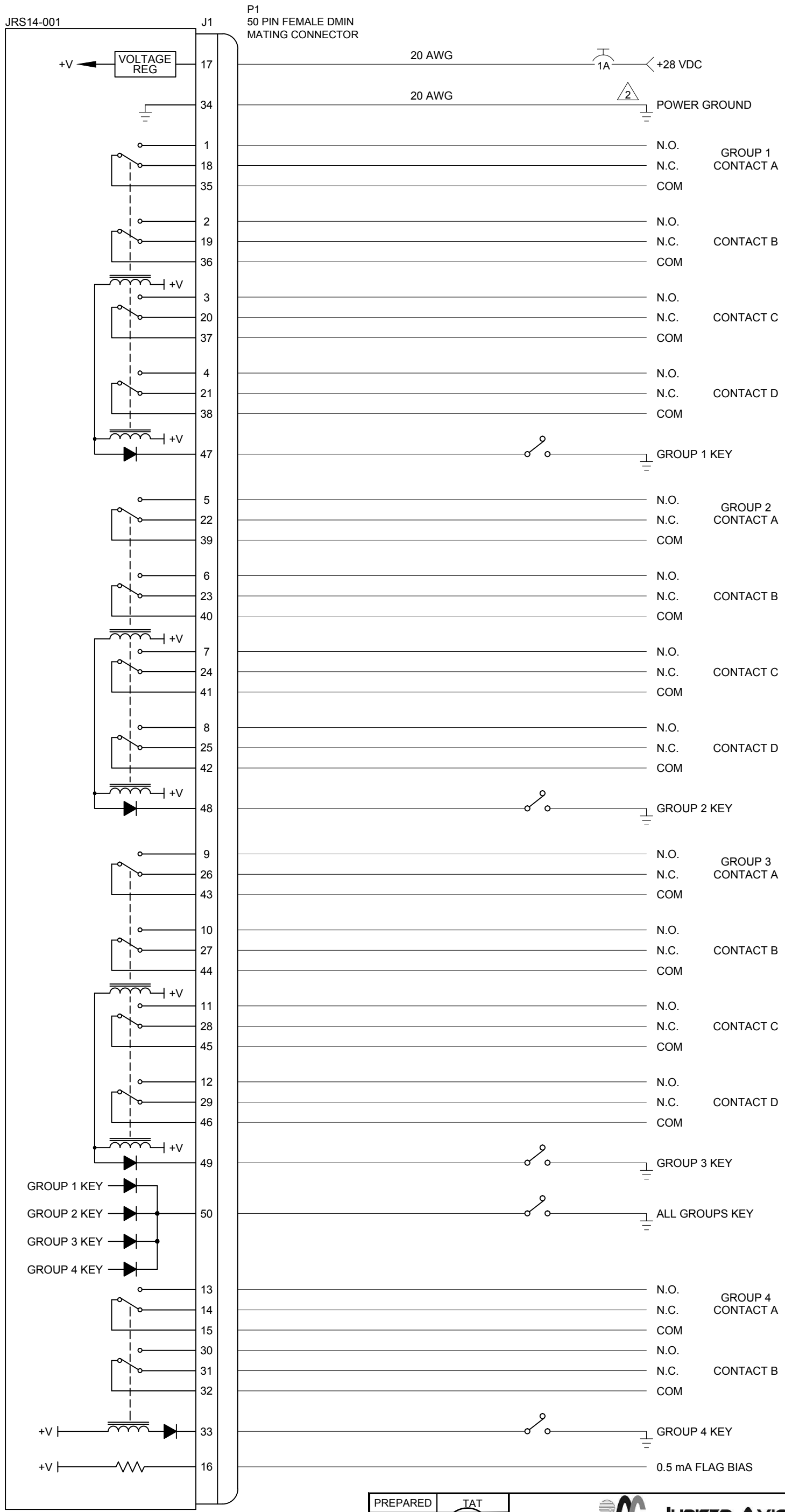

PREPARED	TAT			TITLE	Relay Switch 28 Contacts
CHECKED	JAC 08-27-14 DS				
APPROVED	JAC 08-27-14 KDV	NCAGE CODE	PART NO.	SHEET	2/3
CONFIDENTIAL & PROPRIETARY TO JUPITER AVIONICS CORP.		L00N3	JRS28-001		
		DOC NO.		JRS28-001 Interconnect Rev B.dwg	

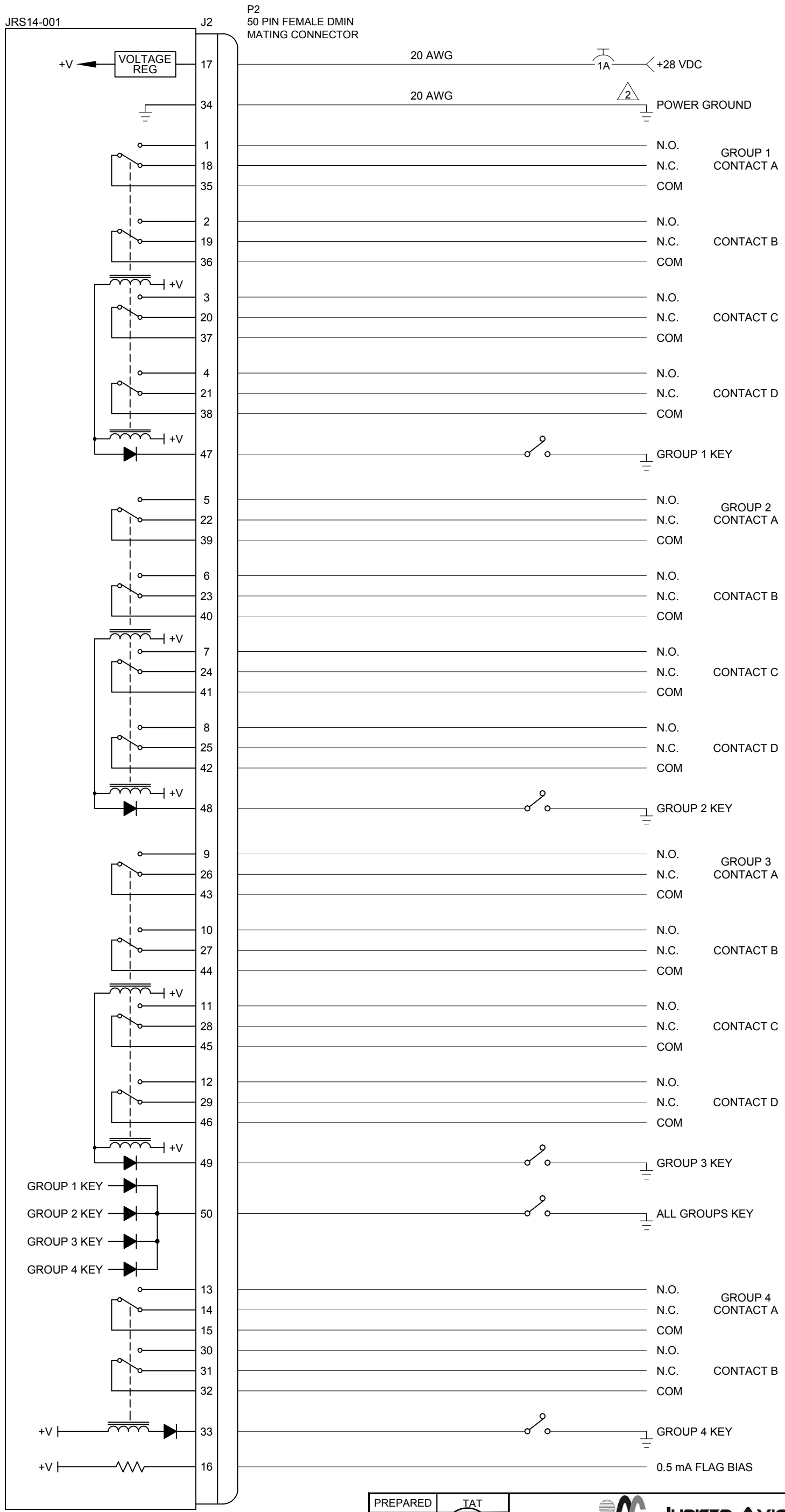

PREPARED	TAT			
CHECKED	JAC 08-27-14 DS			TITLE
APPROVED	JAC 08-27-14 KDV	NCAGE CODE	PART NO.	SHEET 3/3
CONFIDENTIAL & PROPRIETARY TO JUPITER AVIONICS CORP.		L00N3	JRS28-001	
		DOC NO. JRS28-001 Interconnect Rev B.dwg		

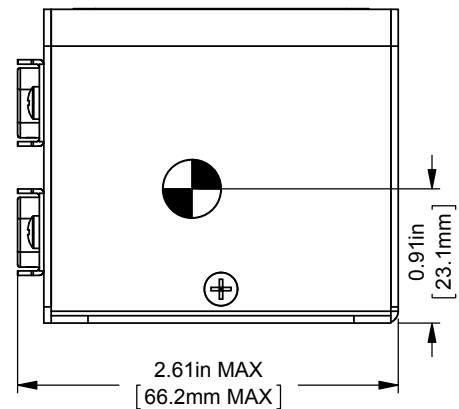
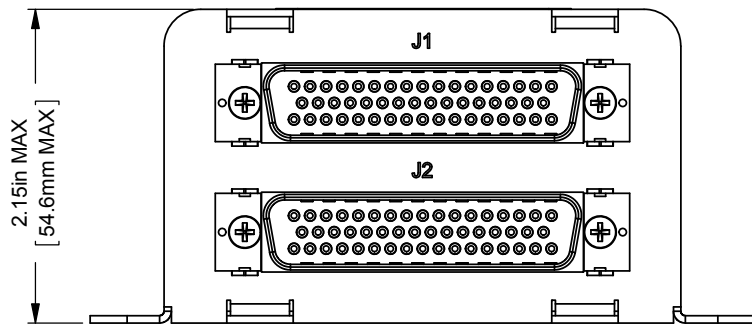
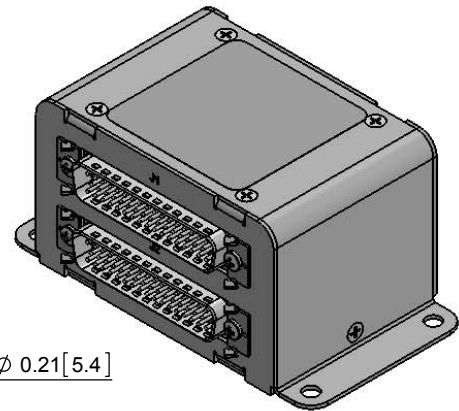
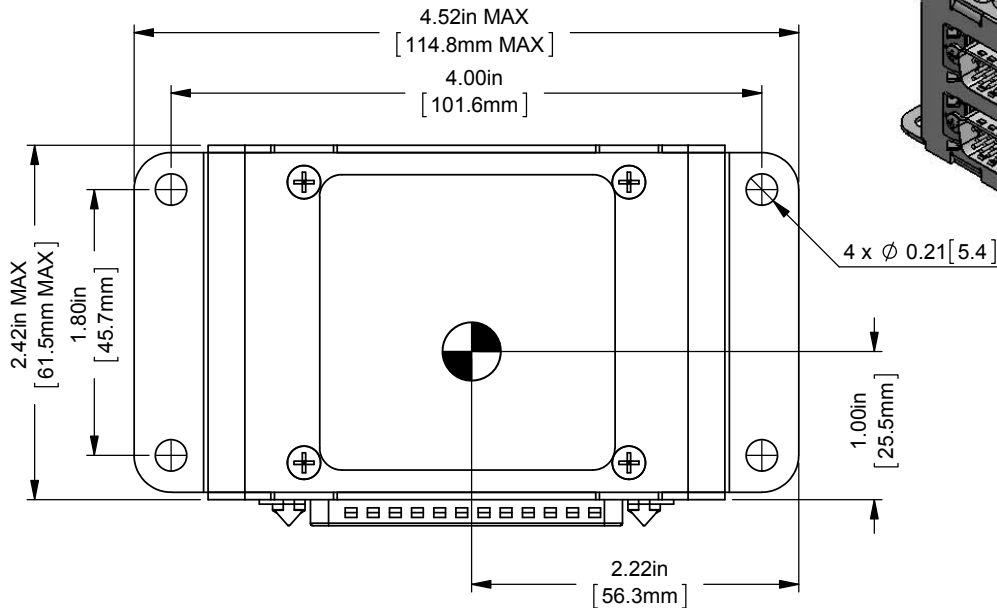



 CENTER OF GRAVITY
 $\pm 0.03\text{in}$ [0.8mm]

WEIGHT: 0.48 lbs [0.22 kg] MAX.

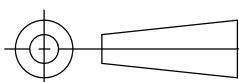
UNLESS OTHERWISE SPECIFIED
 DIMENSIONS ARE IN INCHES
 ANGLES ARE IN DEGREES
 TOLERANCES:
 1 DEC PLACE: ± 0.1
 2 DEC PLACE: ± 0.01
 3 DEC PLACE: ± 0.005
 ANGLES: ± 0.5 DEG



MATERIAL: N/A
 FINISH: N/A

PREPARED	TAT
CHECKED	
APPROVED	
CONFIDENTIAL & PROPRIETARY TO JUPITER AVIONICS CORP. DRAWING NOT TO SCALE	



JUPITER AVIONICS CORPORATION

TITLE

JRS28-001 Mechanical Installation

NCAGE CODE
L00N3

PART NO.
JRS28-001

SHEET
1/1

DOC. NO.
JRS28-001 Mechanical Installation Rev C.SLDDRW